

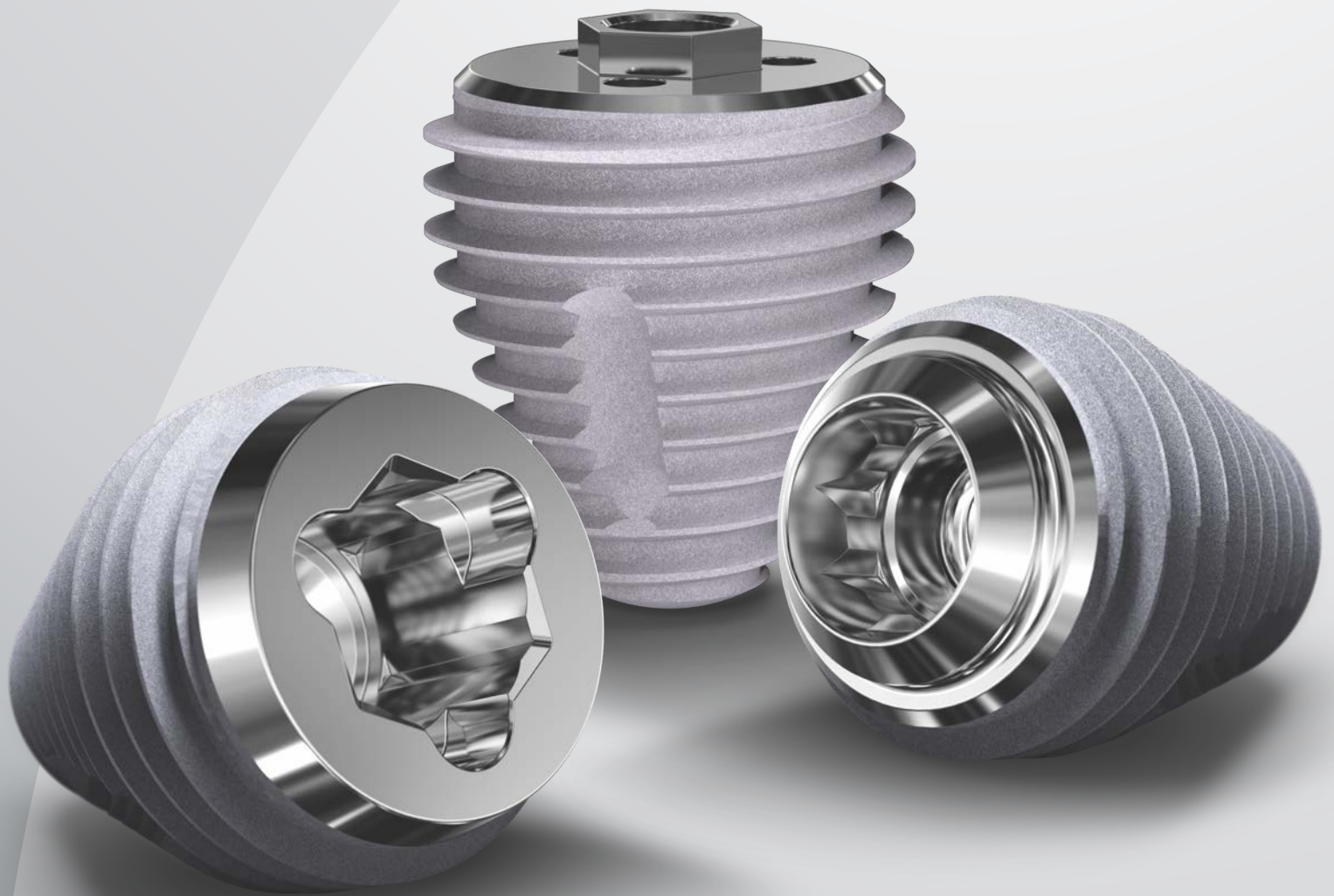

SURGICAL PROTOCOL
SOUTHERNIMPLANTS



MAX IMPLANT

CELEBRATING

25
YEARS

A revolutionary innovation for the immediate placement into a molar extraction socket

The immediate placement of a conventional dental implant into a molar extraction socket **poses a number of difficulties**. Most significantly, the size and shape of the multi-rooted socket is not suited for the optimal placement of a typical implant, often resulting in compromised implant positioning, poor primary stability or the inability to place an implant at all.

This may result in a waiting period of 3-4 months to allow for healing before attempting to place an implant. Often, the healed site presents with reduced bone height, resulting in the need for bone augmentation procedures, especially in the maxilla. This leads to further lengthening of treatment time with **increased cost and complexity**.

An alternative approach has been to place a 6mm diameter implant into one socket of such a multi-rooted site, typically the palatal socket. Problems associated with this approach include adverse biomechanical forces, a poor emergence profile and an unavoidable buccal overhang of the restoration.

The concept of the MAX implant provides for a design of implant and a surgical protocol which makes immediate placement of the implant into a multi-rooted molar socket attainable, thus obviating the multiple problems highlighted.

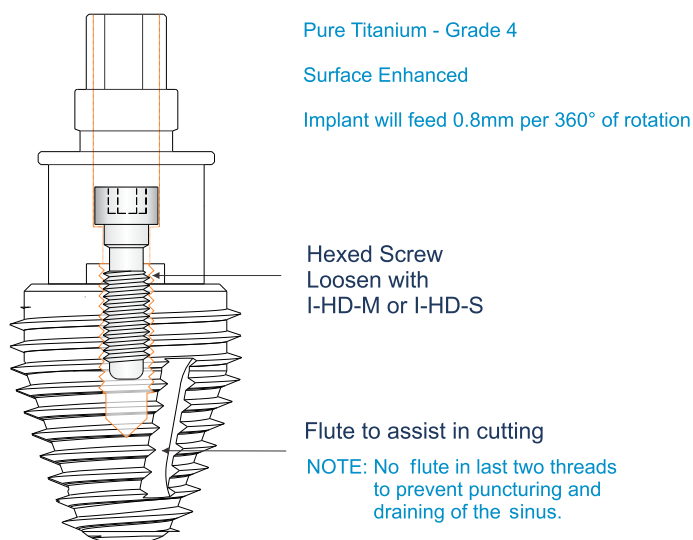

The **MAX implant** features a body with a larger than conventional diameter, achieving primary stability from engagement of the buttresses of bone that protrude from the perimeter bony wall of the molar socket. The greater taper of the MAX implant body allows for maximum preservation and engagement of the inter-radicular bone within the socket of a molar with divergent roots. In the case of a molar tooth with tapering root form, the implant has a natural fit to the socket shape. The tapered geometry of the implant facilitates the excellent primary stability achieved by this threaded implant body.

The MAX implant won an **AO presentation award for innovation** in 2008, the **SABS Design Excellence Award** in 2010, and was the **first FDA approved dental implant for the immediate placement into a molar socket**.

The pioneers of the Max implant have developed and published an innovative surgical protocol which is now commonly used for such site preparation.

The steps are:

1. De-coronate the crown with a high speed burr.
2. Select the position for the central axis of the implant (such that the implant will be at least 2mm and preferably 3 or 4 mm from the buccal plate) with a round burr or other implant site initiating burr, drill a pilot hole through the remnant tooth, into the roots and underlying bone. Take the drill down to half the depth of the roots of the tooth.
3. Follow the initiating drill with a 2mm pilot drill, still drilling through the remnant tooth, into the roots and underlying bone. Due to the presence of these roots and tooth remnants, the drills are easily controllable.
4. Follow this with a tapered spade drill such as D-40TP-10, D-410T or D-L-35-10, to enlarge the site and to start giving it a tapered form.
5. With a high speed burr, split the remnant tooth accordingly to the root anatomy and elevate towards the central hole that has been created.
6. Examine the site and remove any tooth fragments, debride any infectious areas and assess the site for suitability to proceed.
7. Assess which is the smallest Max diameter and length that might achieve "Primary Stability" and continue the site preparation for this "smallest" implant.
8. This is often best done by the immediate transition to the dedicated D-TAP for that chosen implant. If the bone is hard, (as in a mandibular site), drilling might first be needed, with the dedicated Max drill for that implant.
9. Stability can be judged with the D-TAP. If stability is insufficient, a longer or wider Max size can be selected until stability is indicated.
10. After judgement with the D-TAP, remove the tap, open the appropriate implant, and slowly rotate it into the site, until it reaches final depth.

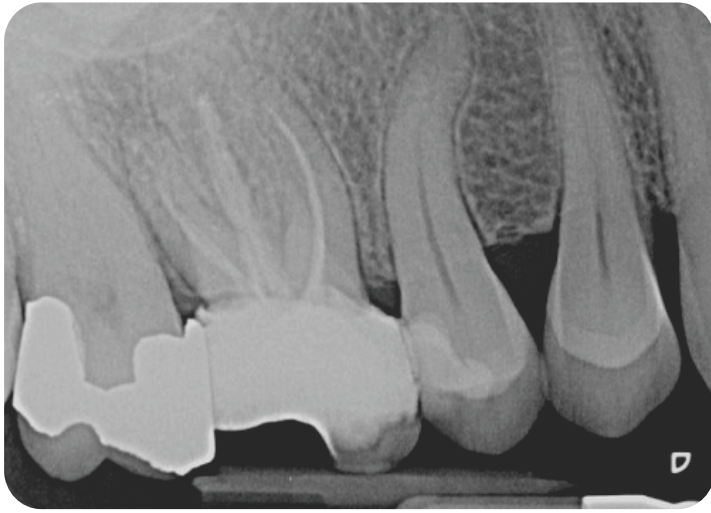

A maxillary first molar to be removed



De-corinate the molar tooth



Start site preparation
round burr or harpoon type initiation drill



2mm twist drill



3.5 or 4mm tapered drill
(a 5mm tapered drill is optional)

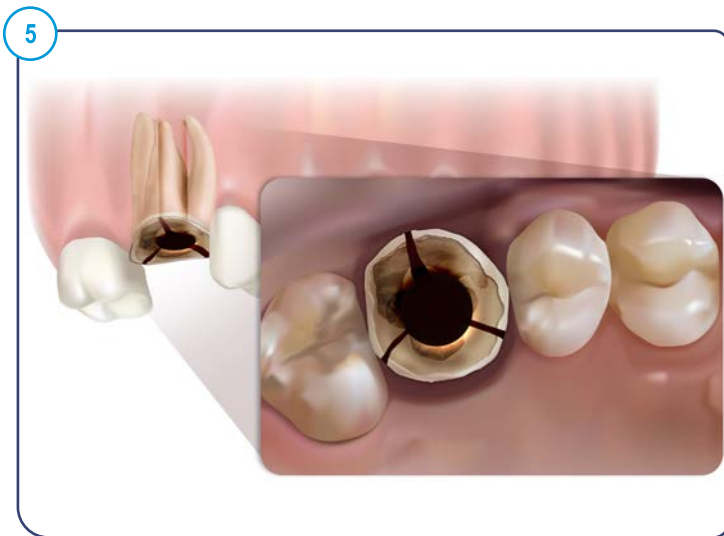

Spilt roots with high speed burr and elevate root remnants

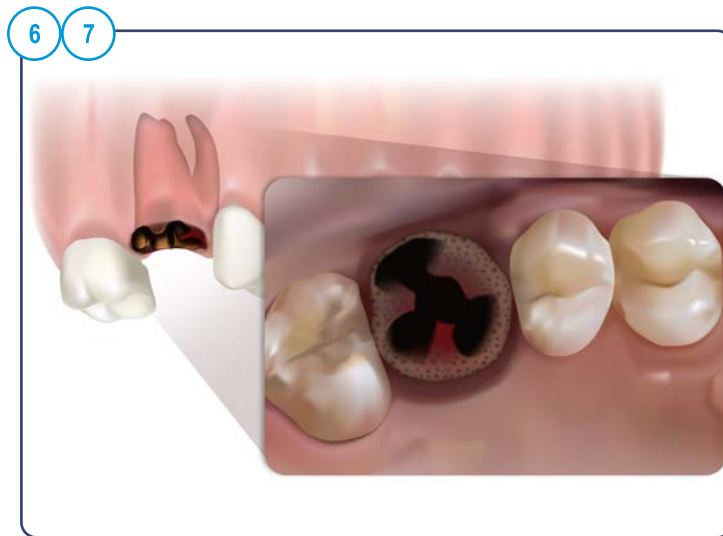

Examine socket and ensure all remnants and any infection is removed

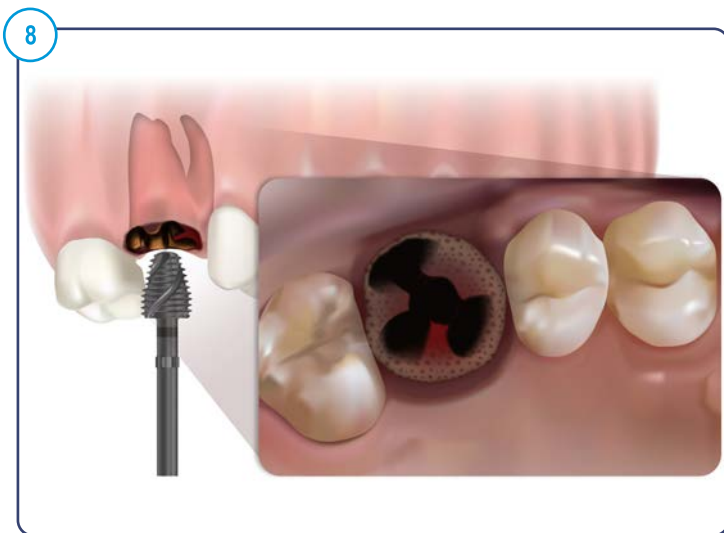

Introduce tap into socket and tap the site to ideal depth of implant

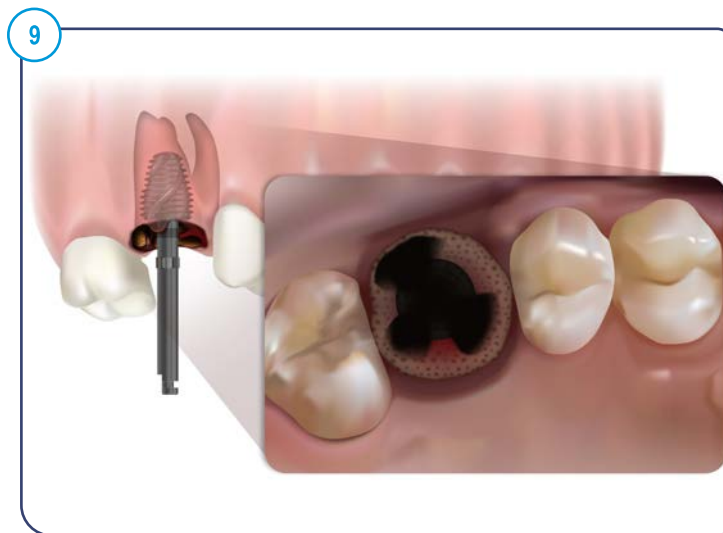

If the tap is not stable, move to the next size up tap



Ensure that the molar socket is intact and that the buccal plate is not cracked



Introduce the implant until it is stable and 1mm below the lowest part of ridge

South Africa
Southern Implants (Pty) Ltd.
Tel: +27 12 667 1046
Fax: +27 12 667 1029
info@southernimplants.com

America / Asia
Southern Implants Inc.
Tel: +1 949 273 8505
Fax: +1 949 273 8508
info@southernimplants.us

Australia
Henry Schein | Halas Dental
Tel: +61 2 9697 6288
Fax: +61 2 9697 6250
info@henryschein.com.au

United Kingdom
Southern Implants UK
Tel: +44 208 899 6847
Fax: +44 208 899 6843
info@southernimplants.co.uk

Austria
Pluradent Austria
Tel: +43 (0) 1/5 44 15 94
Fax: +43 (0) 1/5 44 08 87
wien@pluradent-austria.at

Benelux
Proscan
Tel: +32 11 822 650
Fax: +32 11 822 651
info@proscan.be

Greece
Southern Implants
Tel: +30 210 898 2881
Fax: +30 210 898 2232
info@southernimplants.gr

Germany
Southern Implants,
Vertriebs GmbH
Tel: +49 7121 490 620
Fax: +49 7121 491 717
info@southernimplants.de

Italy
Southern Implants / S.I.R. srl
Tel: +39 346 227 1165
Fax: +39 045 568 351
info@southernimplants.it

Namibia
Skydancer
Tel: +264 61 235 630
Fax: +264 88 613 840
implants@skydancer-cc.com

New Zealand
Ostralos
Tel: 0800 2 46752
Fax: 0800 2 IMPLANT
sales@ostralos.com

Nordic Countries
Protera Dental AB
Tel: +46 312 96600
Fax: +46 706 150 078
info@protera.se
villy@protera.se

Portugal / Spain
Contactodent
Tel: +351 214 693 332
Fax: +351 214 693 329
southernimplants@sapo.pt

Russia
Southern Implants
Scientific Centre IVS
Tel: +7(495) 649 1732
Fax: +7(495) 789 9133
info@southernimplants.ru

Switzerland
Southern Implants
www.southernimplants.ch

Turkey
Bioport Co
Tel: +90 212 272 7577
Fax: +90 212 272 7628
info@bioport.com.tr

UAE
Southern Implants JTL
Tel: +971 50 857 0357
Fax: +971 4 427 5011
info@southernimplants.net